

# OPERATOR'S MANUAL

# 650110-X

INCLUDING: OPERATION, INSTALLATION & MAINTENANCE

INCLUDE MANUAL: S-632 GENERAL INFORMATION MANUAL (PN 97999-624)

**2" AIR MOTOR**  
**2:1 RATIO**  
**6" STROKE**

## 2" DIFFERENTIAL TRANSFER PUMP

(CARBON STEEL)  
SEE CHART BELOW

# 650115-X

RELEASED: 3-26-68  
REVISED: 9-28-11  
(REV. T)



**READ THIS MANUAL CAREFULLY BEFORE INSTALLING,  
OPERATING OR SERVICING THIS EQUIPMENT.**

It is the responsibility of the employer to place this information in the hands of the operator. Keep for future reference.

### SERVICE KITS

- Use only genuine ARO® replacement parts to assure compatible pressure rating and longest service life.
- 66098 for repair of 60702 air motor section.
- 637028 for repair of 66198 lower pump end (650110-C) and 66200 lower pump end (650115-C) (UHMW-PE / Polyethylene).
- 637029 for repair of 66198-1 lower pump end (650110-1C) and 66200-1 lower pump end (650115-1C) (PTFE / PTFE).

### SPECIFICATIONS

<b>Model Series</b> .....	65011X-()
<b>Type</b> .....	Air Operated, Transfer Pump
<b>Ratio</b> .....	2:1
<b>Air Motor Diameter</b> .....	2" (5.08 cm)
<b>Stroke (double acting)</b> .....	6" (15.24 cm)
<b>Air Inlet (female)</b> .....	1/4 - 18 N.P.T.F. - 1
<b>Material Outlet (female)</b> .....	1/2 - 14 P.T.F. SAE Spec. Short
<b>Material Inlet (female) (650115-X)</b> ...	1 - 11-1/2 N.P.T.F.
<b>Pump Construction</b> .....	Carbon Steel
<b>Pump Drum Size / Capacity</b>	
650110-C & 650110-1C .....	55 gallon
650115-C & 650115-1C .....	16 gallon
<b>Dimensional Data</b> .....	see chart

### PERFORMANCE

<b>Air Inlet Pressure Range</b> .....	0 - 150 p.s.i. (0 - 10.3 bar)
<b>Fluid Pressure Range</b> .....	0 - 300 p.s.i. (0 - 20.7 bar)
<b>Cycles / Minute Rec'd @ Working Flow</b>	120
<b>Displacement In<sup>3</sup> Per Cycle</b> .....	8.0
<b>Volume / Cycle</b> .....	4.4 oz. (131 ml)
<b>Cycles Per Gallon</b> .....	28.9
<b>Accessories Available</b> .....	61113 mounting bracket
<b>Noise Level @ 90 p.s.i. - 40 c.p.m</b> .....	81 db(A) ①

① The pump sound pressure level has been updated to an Equivalent Continuous Sound Level (L<sub>Aeq</sub>) to meet the intent of ANSI S1.13-1971, CAGI-PNEUROP S5.1 using four microphone locations.

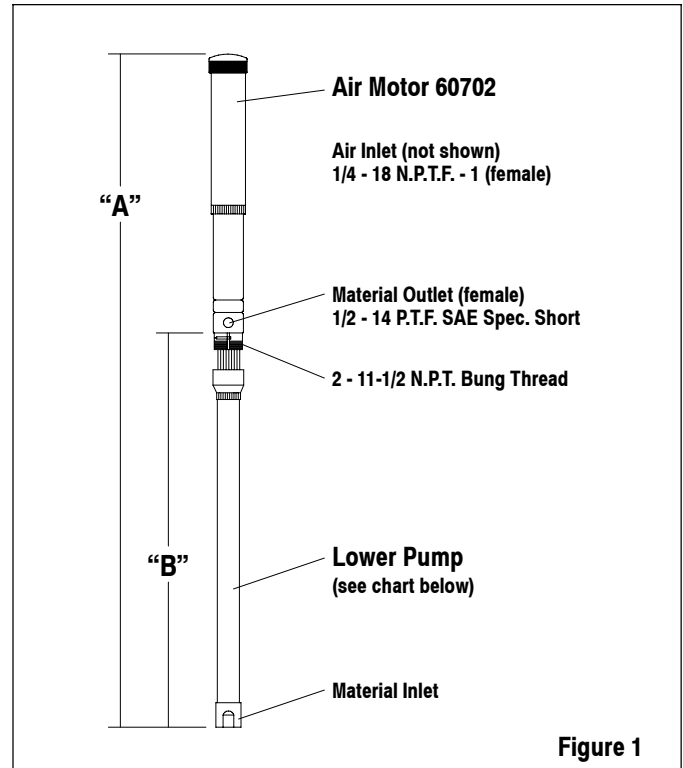

Figure 1

MODEL	LOWER PUMP	"A" Inches (mm)	"B" Inches (mm)
650110-C	66198	53-3/32 (1349)	33-13/16 (859)
650110-1C	66198-1	53-3/32 (1349)	33-13/16 (859)
650115-C	66200	41-1/16 (1043)	21-25/32 (553)
650115-1C	66200-1	41-1/16 (1043)	21-25/32 (553)

## GENERAL DESCRIPTION

The ARO 2" differential, 2:1 ratio transfer pumps have been designed for the application and transfer of a wide range of corrosive and non-corrosive materials. Refer to the lower pump parts list on page 4 for manufactured materials and packings available. These pumps may be directly mounted in the 2" bung of a standard drum or when using a 61113 mounting bracket, the pump can be mounted on the wall or in an open head drum.

The air motor is connected to the lower pump end by a spacer tube, this protects the air motor section from possible contamination due to normal wear and eventual leakage of material past the upper material piston seals.

$$\text{PUMP RATIO X} \\ \text{INLET PRESSURE TO PUMP MOTOR} = \text{MAXIMUM PUMP} \\ \text{FLUID PRESSURE}$$

Pump ratio is an expression of the relationship between the pump motor area and the lower pump end area. EXAMPLE: When 150 p.s.i. (10.3 bar) inlet pressure is supplied to the motor of a 2:1 ratio pump it will develop a maximum of 300 p.s.i. (21 bar) fluid pressure (at no flow) - as the fluid control is opened, the flow rate will increase as the motor cycle rate increases to keep up with the demand.

Refer to General Information sheet for safety precautions and important information.

## PUMP SERVICE PROCEDURES

### PUMP DISASSEMBLY

Refer to Figure 2.

NOTE: All threads are right hand.

1. Thread a 1/2" nipple into the material outlet.
2. Place the 2" differential pump assembly in a vise as shown. Rotate the pump assembly so that the 1/2" nipple is resting against the vise.

**CAUTION: Do not clamp the pump tightly.**

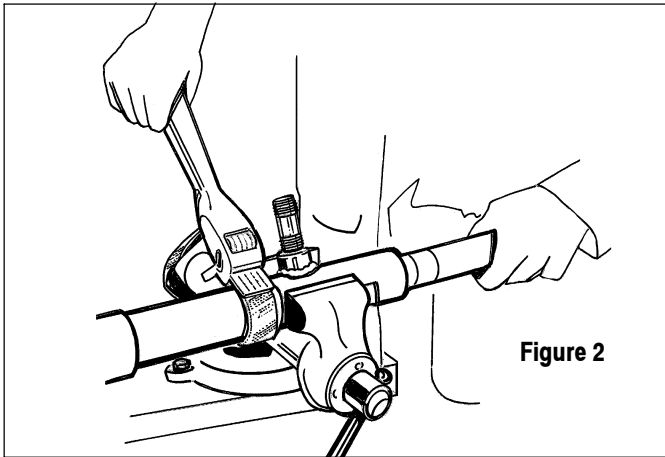

3. Unthread the air motor from the material outlet body by using a strap wrench on the air motor separating tube.
4. Push the connecting rod, in the lower pump assembly, to one side and pull down until the air motor separates from the lower pump assembly.
5. The pump is now in two assemblies: air motor and lower pump assembly.

### PUMP REASSEMBLY

Refer to Figure 3.

1. Place the 2" air motor in a vise with the needle valve or pipe nipple resting against the jaws of the vise, as shown.
2. Insert the 90826 tip of the lower pump assembly into the 76216 separating tube of the air motor.
3. Insert the 90826 tip of the lower pump assembly through the outside edge of the slot in the 76208 plunger tip, center the 90826 tip in the 76208 plunger tip and pull out until the 90826 tip is retained.
4. Thread the air motor into the material outlet body and tighten by using a strap wrench on the air motor 76216 separating tube.

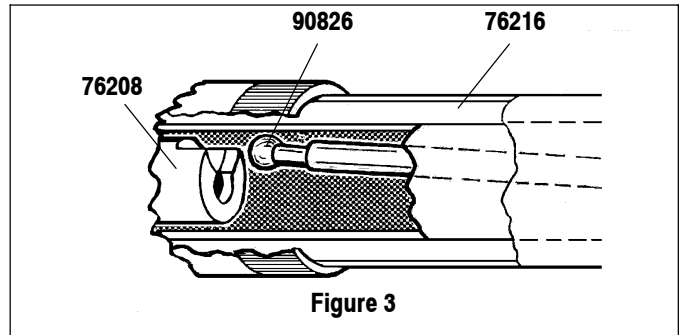

## 2" AIR MOTOR SERVICE PROCEDURES

### 2" AIR MOTOR DISASSEMBLY

Refer to Figure 4.

NOTE: All threads are right hand.

1. Place the air motor in the vise with a needle valve or a 1/4" pipe nipple resting against the jaws of the vise, as shown.
2. Place a strap wrench around the (1) cap and remove the cap. NOTE: If the (6) cylinder comes off with (1) cap, place the cap in a vise and use a strap wrench around the cylinder and unscrew from cap. NOTE: Do not squeeze or use pipe wrench on (6) cylinder.
3. Place a strap wrench around the (6) cylinder and unscrew and remove the cylinder.
4. Pull the (7) spacer and piston assembly and (15) plunger out of the (18) pump body and lay aside.
5. Remove the (17) valve spring and (16) "O" ring from the (18) pump body.
6. Place the (18) pump body in the vise and loosen the (21) lock ring with a strap wrench.
7. Place a strap wrench around the (22) separating tube and unthread.
8. Remove the (20) washer and (19) "O" ring from the (18) pump body.
9. Clamp the flats of the (7) spacer and piston assembly in the vise. Remove the plunger tip from the (7) spacer and piston assembly. NOTE: Do not remove the (13) plunger tip from the (15) plunger, unless replacing parts.

10. Remove the (12) gasket from the (13) plunger tip. NOTE: Do not mar or damage o.d. of (15) plunger.
11. Remove the three (8) screws from the spacer and piston assembly.
12. Remove the (9) valve plate and (11) valve spacer.

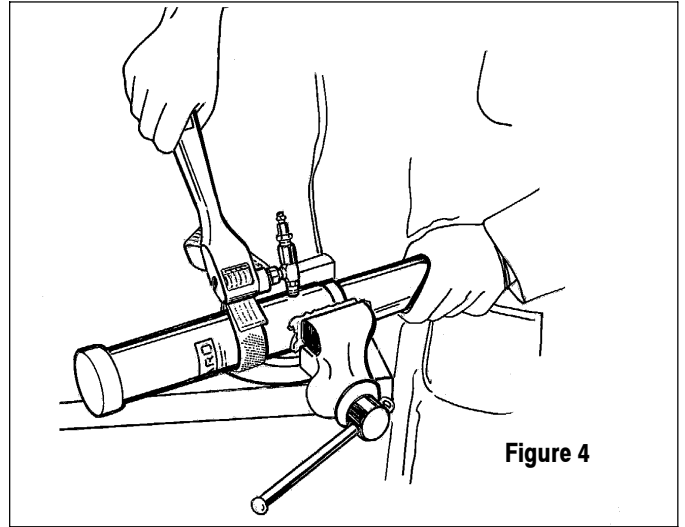

Figure 4

## 60702 2" AIR MOTOR PARTS LIST

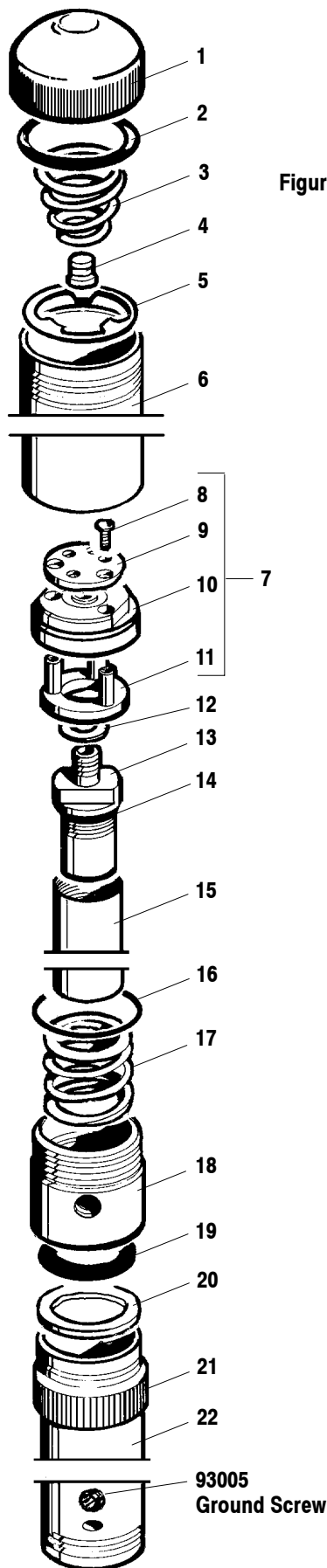

Figure 5

Item	Description (size)	Qty	Part No.
✓	<b>Service Kit Parts</b>		<b>66098</b>
1	Cap	1	76073-2
✓ 2	"O" Ring (3/32" x 2-5/16" o.d.)	1	Y325-138
3	Spring	1	77208
4	Button	1	90638
5	Washer	1	77290
6	Cylinder	1	76074-2
✓ 7	<b>Spacer &amp; Piston Assembly</b>	1	<b>61088</b>
8	Screw (#4 - 40 x 3/8")	3	Y222-54-C
9	Valve Plate	1	76090
10	Piston Assembly	1	60656
11	Valve Spacer	1	76856
✓ 12	Gasket	1	F21-53
13	Plunger Tip	1	76208
14	"O" Ring (1/8" x 1-1/4" o.d.)	1	Y325-214
15	Plunger	1	76215
✓ 16	"O" Ring (3/32" x 2-1/16" o.d.)	1	Y325-134
17	Valve Spring	1	76070
18	Pump Body	1	76077-2
✓ 19	"O" Ring (0.275" x 1.837" o.d.)	1	77803
20	Washer	1	76075
21	Lock Ring	1	76100
22	Separating Tube	1	76216

### 2" AIR MOTOR REASSEMBLY

Refer to Figure 5.

1. Insert the (11) valve spacer through the bottom of the (10) piston assembly.
2. Place the (9) valve plate on top of the (10) piston assembly (side with three protrusions) to face (10) piston assembly and align the three holes with the three posts of the (11) valve spacer.
3. Fasten the (9) valve plate down with the three (8) screws (this is the (7) spacer and piston assembly). Lay aside.
4. Thoroughly grease the (19) "O" ring and place into the (18) pump body.
5. Place the (20) washer in the (18) pump body.
6. Screw the (22) separating tube securely to the (18) pump body.
7. Tighten the (21) lock ring.
8. Grease the (16) "O" ring and place over the threads of the (18) pump body.
9. Place the (17) valve spring into the (18) pump body.
10. Place the (15) plunger with (13) plunger tip through the (22) separating tube and through the (18) pump body. NOTE: To prevent damage to (19) "O" ring apply light film of grease on (15) and (13) assembly.
11. Place the (12) gasket over the threads of (13) plunger tip.
12. Screw the (7) spacer and piston assembly onto the (13) plunger tip and tighten with wrenches, using flats provided.
13. Thoroughly grease the inside of the (6) cylinder and insert it over the (7) spacer and piston assembly.
14. Thread the (6) cylinder on the (18) pump body.
15. Screw the (1) cap, with (2) "O" ring, (3) spring, (4) button and (5) washer, in place on the (6) cylinder and tighten with a strap wrench.

## LOWER PUMP SERVICE PROCEDURES

### LOWER PUMP DISASSEMBLY

Refer to Figure 6.

NOTE: All threads are right hand.

1. Clamp the lower pump assembly in the vise on solid part of (28) pump body. **CAUTION: Clamp the pump so that the three small tubes connected to the lower end of (28) pump body are not being twisted.**
2. Place a pipe or strap wrench on the knurled part of the (32) suction tube and remove the (32) suction tube. **CAUTION: Do not place wrench any other place other than the knurled part of the (32) suction tube.**
3. Grasp the (41) lower piston rod and remove the rod and piston assembly by pulling straight out.
4. Place a socket wrench in the hex end of the (40) inner suction tube and remove. **CAUTION: Do not use any open end or adjustable wrench.**
5. Remove the (30 and 31) gaskets.
6. Loosen the vise and reclamp the pump on the (28) pump body in area of material outlet hole. **CAUTION: Do not clamp directly on outlet hole.**
7. Remove (27) tube and washer assembly with a strap wrench.
8. Remove the (24) Truarc ring using Truarc pliers.
9. Remove the (25) washer.
10. Remove the (26) "U" cup.
11. Clamp the (49) foot valve body on flats in vise.
12. Place a pipe wrench on the knurled portion of (32) suction tube. **CAUTION: Do not place wrench any other place other than the knurled part of the (32) suction tube.**
13. Remove (32) suction tube from (49) foot valve body.
14. Remove (49) foot valve body from vise.
15. Remove (47) ball stop.
16. Remove (48) ball.
17. Clamp the (41) lower piston rod in the vise on flats.
18. Place an open end or adjustable wrench on (34) connecting rod flats. Remove by turning counterclockwise.
19. Remove the (38) washer.
20. Remove the (39) piston.
21. Remove the (46) elastic stop nut.

22. Remove the (45) washer.

23. Remove the (44) piston.

### LOWER PUMP END REASSEMBLY

Refer to Figure 6.

**CAUTION: Apply anti-seizing compound to all stainless steel threads unless the service manual calls for loctite.**

1. Clamp the (41) lower piston rod on flats in vise. Put the (44) piston in place as shown (lips up).
2. Put the (45) washer and (46) elastic stop nut in place.
3. Place the (39) piston (lips down) on the (41) lower piston rod.
4. Place the (38) washer on the (41) lower piston rod.
5. Thread the (34) connecting rod to (41) lower piston rod and tighten.
6. Clamp on (28) pump body below the three small tubes. Place the (30 and 31) gaskets in the (28) pump body.
7. Thoroughly grease the inside of the (40) inner suction tube and thread securely into the (28) pump body.
8. Thoroughly grease the (39 and 44) pistons. Insert the (34) connecting rod through the (40) inner suction tube and (28) pump body, (33) tip end first.
9. Thoroughly grease the inside of the (32) suction tube.
10. Insert the (32) suction tube over the (44) piston and thread into the (28) pump body.
11. Place the (48) ball into the (49) foot valve body.
12. Insert the (47) ball stop into the (49) foot valve body.
13. Thread the (49) foot valve body into the (32) suction tube.
14. Tighten the lower pump section by placing a bar in the bottom slot in the (49) foot valve body and turn clockwise.
15. Thoroughly grease and install the (26) "U" cup into the (27) tube and washer assembly.
16. Place the (25) washer into the (27) tube and washer assembly.
17. Insert the (24) Truarc ring into the (27) tube and washer assembly.
18. Insert the (27) tube and washer assembly over the (33) tip and thread into the (28) pump body.

## LOWER PUMP END PARTS LIST

Item	Description (size)	Qty	Part No.	Mtl
◇	Items included in service kit		637028	
□	Items included in service kit		637029	
24	Truarc Ring	1	76243-1	[C]
25	Washer	1	76214	[Br]
◇□ 26	"U" Cup (1/8" x 3/4" o.d.)	1	Y186-47	[B]
27	Tube & Washer Assembly	1	60708	[C]
28	Pump Body (66198-X)	1	61617	[C]
	(66200-X)	1	61618	[C]
29	Bung Adapter Ass'y (includes 50)	1	60870	[C]
◇□ 30	Gasket	1	91419	[Ny]
◇□ 31	Gasket	1	91491	[Ny]
32	Suction Tube (66198-X)	1	76245	[C]
	(66200-X)	1	76245-1	[C]
33	Tip	1	90826	[C]
34	Connecting Rod (66198-X)	1	92153	[C]
	(66200-X)	1	92152	[C]
35	Rod & Heli-Coil Ass'y (includes 34 & 36)			
	(66198-X)	1	91571	
	(66200-X)	1	91570	
36	Heli-Coil	1	91450	[SS]

Item	Description (size)	Qty	Part No.	Mtl
37	Rod Assembly (includes 33 & 35)			
	(66198-X)	1	66254	
	(66200-X)	1	66253	
38	Washer	1	91487	[SS]
◇ 39	Piston Kit (66198 & 66200)	1	93848-1	[UH]
	(66198-1 & 66200-1)	1	93848-2	[T]
40	Inner Suction Tube	1	76242	[C]
41	Lower Piston Rod (66198-X)	1	91569	[C]
	(66200-X)	1	91569-1	[C]
42	Nut (3/8" - 24)	1	Y11-106-T	[SS]
43	Adapter	1	91485	[SS]
◇ 44	Piston (66198 & 66200)	1	91523	[UH]
	(66198-1 & 66200-1)	1	91484	[T]
45	Washer	1	91489	[SS]
46	Elastic Stop Nut (3/8" - 24)	1	Y115-14	[SS]
47	Ball Stop	1	76231	[SH]
48	Ball (0.8125" o.d.)	1	Y16-226	[C]
49	Foot Valve Body (66198-X)	1	76207	[C]
	(66200-X)	1	90931	[C]
50	Thumb Screw (1/4" - 20 x 1-1/2")	1	Y197-158-C	[C]

# LOWER PUMP END PARTS LIST

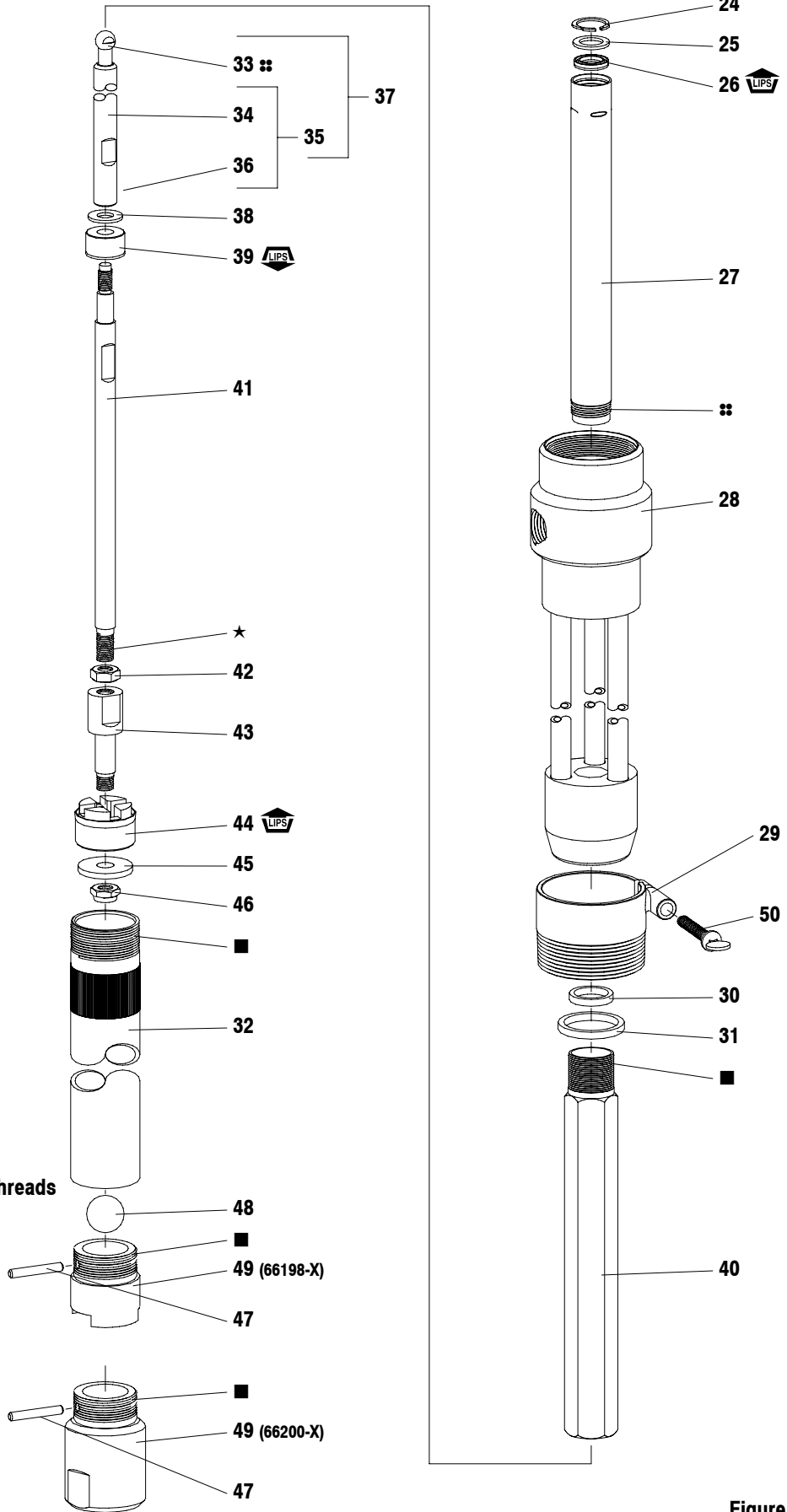
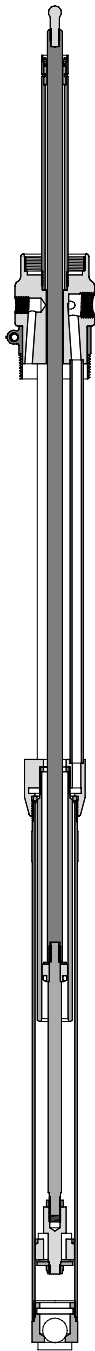

**\*\* Apply Loctite® 271 to threads.**

**\* Apply Loctite Nickel Anti-Seize to threads**

**■ Apply PTFE tape to threads.**

MATERIAL CODE	
[B]	= Nitrile
[Br]	= Brass
[C]	= Carbon Steel
[L]	= Leather
[Ny]	= Nylon
[SH]	= Hardened Stainless Steel
[SS]	= Stainless Steel
[T]	= PTFE
[UH]	= UHMW-PE

**Figure 6**

---

## TROUBLE SHOOTING

---

### Pump continually cycles.

- Check for empty material supply. Disconnect the air (from the pump) replenish material supply.
- Check to see if the connecting rod has disassembled from the mating rod. See assembly of lower pump end (figure 3).
- The (48) ball may be wedged or sticking open in the foot valve body. NOTE: Replace the ball or the foot valve if either are damaged.
- Check for worn or damaged (39) upper piston.

### Material on one stroke only (fast downstroke).

- The ball in the foot valve may not be checking or sealing properly. Remove the ball from foot valve and inspect. If the ball or foot valve is damaged replace with new parts. If the ball or foot valve is not damaged, thoroughly clean both parts and reassemble (See lower pump end instructions).

### Material on one stroke only (fast upstroke).

- Check for worn or damaged (44) lower material piston. Replace piston (See lower pump end instructions). See Figure 6.

### Material leakage out the top of the pump body.

- Check for worn or damaged (39) upper piston. See lower pump end instructions and replace the upper piston.
- Remove (48) ball from the (49) foot valve body. Thoroughly clean and replace (see figure 6).

### Air leakage out of the exhaust holes. (See Air Motor Instructions)

- Check to see if the (9) valve plate is loose or has disassembled from the (11) valve spacer.
- Check for worn or damaged (10) piston assembly.
- Check for worn or damaged (19) "O" ring.
- Check for worn or warped (9) valve plate.
- Worn or damaged (14) "O" ring. Replace (14) "O" ring.

---

## OPTIONAL ACCESSORIES

---

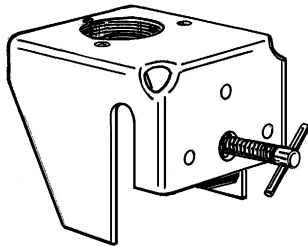

61113 MOUNTING BRACKET

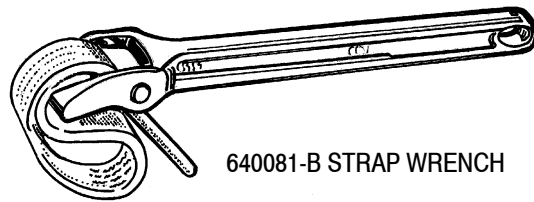

640081-B STRAP WRENCH

Figure 7

